

6487

Picoammeter/Voltage Source



The 5½-digit Model 6487 Picoammeter/Voltage Source improves on the measurement capability of the award-winning Model 6485, and adds a high resolution 500V source. It provides higher accuracy and faster rise times than the 6485, as well as a damping function for use with capacitive devices. With eight current measurement ranges and high speed autoranging, this cost-effective instrument can measure currents from 20fA to 20mA, take measurements at speeds up to 1000 readings per second, and source voltage from 200μV to 505V.

The Model 6487's 10fA resolution, superior sensitivity, voltage sweeping, and Alternating Voltage resistance measurements make it well suited for characterizing low current devices. Using the latest current measurement technology, it is significantly less expensive than other instruments that perform similar functions, such as optical power meters, tera-ohmmeters, competitive picoammeters, or user-designed solutions. With a price that's comparable to a high-end DMM, the Model 6487 makes picoamp-level measurements affordable for virtually any laboratory or production floor.

- 10fA resolution
- 5½-digit resolution
- <200μV burden voltage
- Alternating Voltage method ohms measurements
- Automated voltage sweeps for I-V characterization
- Floating measurements up to 500V
- Up to 1000 readings/second
- Built-in Model 486 and 487 emulation mode
- IEEE-488 and RS-232 interfaces
- Analog output
- Digital I/O
- Driver for LabVIEW™, LabWindows™/CVI, Visual Basic, C/C++, and TestPoint™ included
- ExceLINX™ Excel Add-In included

Low Voltage Burden and Higher Accuracy

While DMMs typically employ shunt ammeter circuitry to measure current, the Model 6487 is a feedback picoammeter. This design reduces voltage burden by several orders of magnitude, resulting in a voltage burden of less than 200μV on the lower measurement ranges. The low voltage burden makes the Model 6487 function much more like an ideal ammeter than a DMM, so it can make current measurements with high accuracy, even in circuits with very low source voltages.

Successor to the Model 487

The Model 6487 builds on the strengths of one of Keithley's most popular picoammeters, the Model 487, offering an additional 20mA measurement range, as well as much higher measurement speeds, up to 1000 readings per second. It simplifies device characterization with built-in voltage sweeping capability and the Alternating Voltage method for high resistances. A time-stamped 3000-reading data buffer provides minimum, maximum, and standard deviation statistics. A built-in emulation mode makes it possible to control the Model 6487 with any custom code written to control the Model 487.

Features that Expand Test and Measurement Flexibility

- **Direct resistance measurements.** Optimized for resistances from 50Ω to 5×10¹⁴Ω using the Source Voltage/Measure Current method.
- **Alternating Voltage method resistance measurements.** This method improves resistance measurements on devices with high background current or high noise. It extends the measurable resistance range up to 10¹⁶Ω.
- **500V overload protection.** This high overload protection and a robust design let the Model 6487 tolerate abusive overflows, including accidentally shorting the voltage source directly into the ammeter.

	Model 487	Model 6487
Current Ranges	2 nA–2 mA	2 nA–20 mA
Voltage Burden	200 μV	200 μV (1 mV on 20 mA range)
Reading Rate	Up to 180/s	Up to 1000/s
Voltage Sweeps	No	Yes
Alternating Voltage Ohms	No	Yes
Analog Output	Yes (non-inverting)	Yes (inverting)
Storage Buffer	512 points	3000 points
Best V Source Resolution	1 mV	0.2 mV

Measures low currents quickly, accurately, and economically

LOW I/HIGH R PRODUCTS

1.888.KEITHLEY (U.S. only)

www.keithley.com

KEITHLEY

A GREATER MEASURE OF CONFIDENCE

6487

Ordering Information

6487 Picoammeter/Voltage Source

Accessories Supplied

CAP-31 Protective Shield/Cap (3-lug)

7078-TRX-3 Low Noise Triax Input Cable, 1m (3 ft)

CS-459 Safety Interlock Plug

8607 High Voltage Banana Cable Set for Voltage Source Output

CA-186-1B Ground Connection Cable, Banana to Screw-Lug

APPLICATIONS

- Beam monitoring and radiation monitoring
- Leakage current testing in insulators, switches, relays, and other components
- I-V characterization on semiconductor and optoelectronic devices
- Fiber alignment
- Circuit test and analysis in DCLF circuits
- Sensor characterization

Picoammeter/Voltage Source

- **Rear panel triax input.** This allows the picoammeter to be used in floating operation, up to 500V. When not floating, the addition of a triax to BNC adapter allows inexpensive, easy-to-use BNC cables to be employed, rather than more expensive triaxial cables.
- **RS-232 and IEEE-488 interfaces.** These interfaces make it easy to integrate the Model 6487 into automated test and measurement systems.
- **Scaled voltage analog output.** This output allows the Model 6487 to transmit measurement results to devices like DMMs, data acquisition cards, oscilloscopes, or strip chart recorders.
- **Built-in Trigger Link interface.** The Trigger Link interface simplifies synchronizing the Model 6487 with other instruments and voltage sources. This interface combines six independent selectable trigger lines on a single connector for simple, direct control over all instruments in a system.
- **Display on/off switch.** For research on light-sensitive components, such as measuring the dark currents of photodiodes or I-V measurements on unpackaged semiconductors, the front panel display can be switched off to avoid introducing light that could significantly reduce the accuracy of the results.
- **One-touch front panel design.** Functions can be configured easily with the push of a button, without complicated function menus.
- **Digital calibration.** Using the Model 5156 Calibration Standard, the instrument can be calibrated via either the front panel or over the IEEE-488 bus.

A Broad Range of Low Current Applications**Wafer-Level Photodiode Testing**

The Model 6487 Picoammeter/Voltage Source can be paired with a calibrated light source and a probing fixture to create a cost-effective photodiode test system. Multiple Model 6487s can be connected to the DUT's probe pads to provide photocurrent readings or, with the addition of a switch matrix, one picoammeter can take current measurements from multiple pads. In the first step of the measurement process, performed in total darkness, the Model 6487 produces a voltage sweep and then measures the resulting dark current. In the second step, a voltage bias is applied and the resulting photocurrent is measured while the light level is increased in calibrated steps. The same basic test configuration can be used for testing positive intrinsic negative (PIN) and avalanche photodiodes (APDs). The 6487's high resolution on the 10V source range provides superior sweeping and biasing when small biases are required. The 500V source capability is necessary to bias APDs.

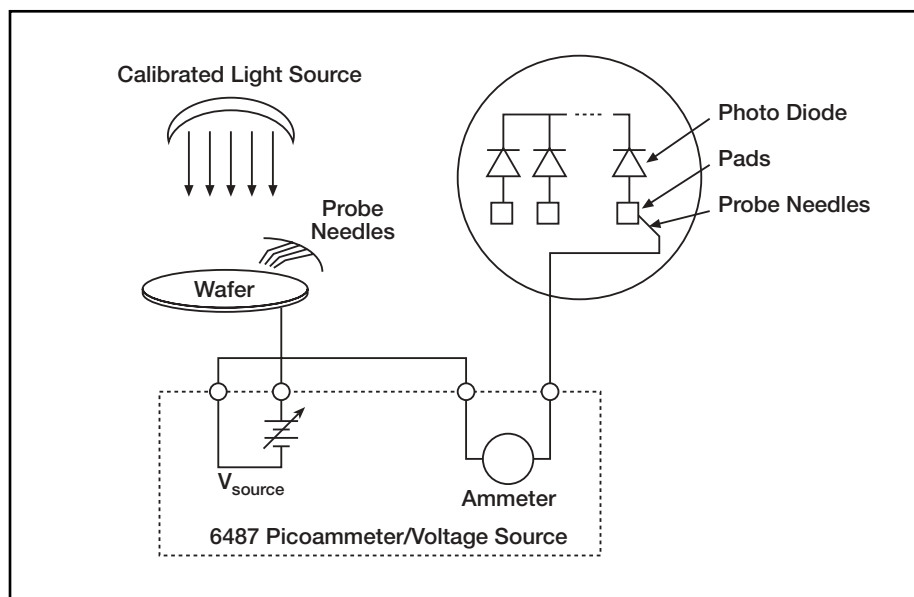

1.888.KEITHLEY (U.S. only)

www.keithley.com**KEITHLEY**

A GREATER MEASURE OF CONFIDENCE

Monitoring and Control of Focused Ion Beam Currents

In semiconductor fabrication, focused ion beam systems are often used for nanometer-scale imaging, micromachining, and mapping. Careful monitoring of the magnitude of the beam current with an ion detector is critical. The ion detector generates a secondary current that's proportional to the current of the primary ion beam. When this secondary current is measured, it can be used to control the intensity of the primary beam. However, this secondary current is very low, often just a few picoamps, so the instrumentation measuring it must provide high measurement accuracy and repeatability, as well as sub-picoamp resolution. The Model 6487's wide measurement range and 5½-digit resolution make it ideal for this application. Signal connections to the Model 6487 are made through the instrument's triax connector. Often, a detector may require high voltage to attract ions, making the 6487's 500V source a necessity.

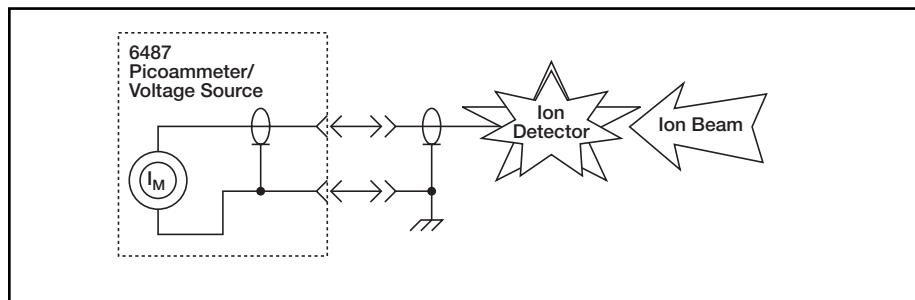

High Resistance Measurements

The Model 6487 Picoammeter can be used to make high resistance (>1G Ω) in applications such as insulation resistance testing. A constant voltage is placed in series with the unknown resistance and the picoammeter. The voltage drop across the picoammeter is negligible, so all the voltage appears across the unknown resistance. The resulting current is measured by the picoammeter and the resistance is calculated using Ohm's Law ($R = V/I$). To prevent generated current due to electrostatic interference, the unknown resistance is housed in a shielded test fixture. A small series resistor may be added to reduce noise if the unknown resistor has high stray capacitance across it.

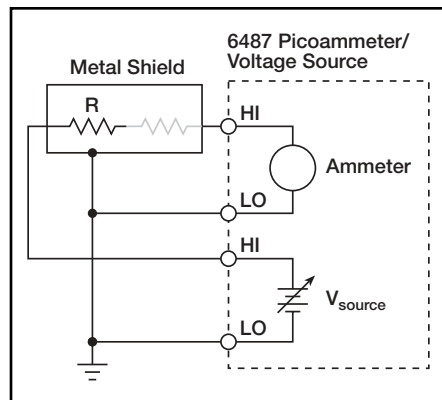

When do you need a picoammeter?

Measuring low DC currents often demands a lot more than a digital multimeter can deliver. Generally, DMMs lack the sensitivity required to measure currents less than 100nA. Even at higher currents, a DMM's input voltage drop (voltage burden) of hundreds of millivolts can make accurate current measurements impossible. Electrometers can measure low currents very accurately, but the circuitry needed to measure extremely low currents, combined with functions like voltage, resistance, and charge measurement, can increase an electrometer's cost significantly. The Model 6487 Picoammeter/Voltage Source combines the economy and ease of use of a DMM with low current sensitivity near that of an electrometer.

Powerful Software Options

To simplify integrating the Model 6487 into PC-based test systems, the instrument comes with Keithley's ExcelINX, an add-in utility for Microsoft® Excel. Within minutes of installing ExcelINX on a PC, users can acquire data directly from the Model 6487 instrument, then employ Excel's graphics, charting, and analysis capabilities to turn that data into useful information. No programming is required to use ExcelINX—a few mouse clicks are all it takes. Keithley also provides a 6487 instrument driver for use with Application Development Environments such as LabVIEW™, LabWindows™/CVI, Visual Basic, C/C++, and TestPoint.

ACCESSORIES AVAILABLE

CABLES

6517-ILC-3	Interlock Cable for 8009 Resistivity Test Fixture
7078-TRX-10	Low Noise Triax Cable, 3.0m (10 ft)
7078-TRX-20	Low Noise Triax Cable, 6.0m (20 ft)
7008.*	IEEE-488 Digital Cable, 0.9m, 1.8m or 3.9m (3 ft, 6 ft, or 13 ft)
7009-5	RS-232 Cable
8607	High Voltage Banana Cable Set for Analog Output
8501.*	Trigger Link Cable with male Micro-DIN connectors at each end, 1m or 2m (3.3 ft or 6.6 ft)
8502	Micro-DIN to 6 BNCs Adapter Box. Includes one 8501-1
8503	DIN-to-BNC Trigger Cable

ADAPTERS

237-TRX-BAR	Triax Barrel
7078-TRX-BNC	Triax-to-BNC Adapter

TEST FIXTURES

8009	Resistivity Test Fixture
------	--------------------------

RACK MOUNT KITS

4288.*	Single or Dual Fixed Rack Mounting Kit
--------	----------------------------------------

OTHER

KPC-TM	Trigger Master Interface
KPCI-488	IEEE-488.2 Interface for PCI Bus
KPC-488.2AT	IEEE-488 Interface Card for IBM PC/AT and PS/2
1050	Padded Carrying Case
5156	Calibration Source

1.888.KEITHLEY (U.S. only)

www.keithley.com

KEITHLEY

A GREATER MEASURE OF CONFIDENCE

Measures low currents quickly, accurately, and economically

LOW I/HIGH R PRODUCTS

RANGE	5½ DIGIT DEFAULT RESOLUTION	ACCURACY (1 Year) ¹ ±(% rdg. + offset) 18°–28°C, 0–70% RH	TYPICAL RMS NOISE ²	TYPICAL ANALOG RISE TIME (10% to 90%) ³	
				DAMPING ⁴ OFF	ON
2 nA	10 fA	0.3 % + 400 fA	20 fA	4 ms	80 ms
20 nA	100 fA	0.2 % + 1 pA	20 fA	4 ms	80 ms
200 nA	1 pA	0.15% + 10 pA	1 pA	300 μs	1 ms
2 μA	10 pA	0.15% + 100 pA	1 pA	300 μs	1 ms
20 μA	100 pA	0.1 % + 1 nA	100 pA	110 μs	110 μs
200 μA	1 nA	0.1 % + 10 nA	100 pA	110 μs	110 μs
2 mA	10 nA	0.1 % + 100 nA	10 nA	110 μs	110 μs
20 mA	100 nA	0.1 % + 1 μA	10 nA	110 μs	110 μs

TEMPERATURE COEFFICIENT: 0°–18°C & 28°–50°C. For each °C, add $0.1 \times (\% \text{ rdg} + \text{offset})$ to accuracy spec.

INPUT VOLTAGE BURDEN: <200μV on all ranges except <1mV on 20mA range.

MAXIMUM INPUT CAPACITANCE: Stable to 10nF on all nA ranges and 2μA range; 1μF on 20μA and 200μA ranges, and on mA ranges.

MAXIMUM CONTINUOUS INPUT VOLTAGE: 505 VDC.

NMRR¹: (50 or 60Hz): 60dB.

ISOLATION (Ammeter Common or Voltage Source to chassis): Typically >1×10¹¹Ω in parallel with <1nF.

MAXIMUM COMMON MODE VOLTAGE (between chassis and voltage source or ammeter): 505 VDC.

ANALOG OUTPUT: Scaled voltage output (inverting 2V full scale on all ranges): 2.5% ±2mV

ANALOG OUTPUT IMPEDANCE³: <100Ω, DC–2kHz.

VOLTAGE SOURCE:

RANGE (Max.)	STEP SIZE (typical)	ACCURACY ⁵ ±(% prog. + offset) 18°–28°C, 0–70% R.H.	NOISE (p-p) 0.1–10 Hz	TEMPERATURE COEFFICIENT	TYPICAL RISE TIME ^{6,8} (10%–90%)	TYPICAL FALL TIME ^{7,8} (90%–10%)
±10.100	200 μV	0.1 % + 1 mV	<50 μV	(0.005% + 20 μV)/°C	250 μs	150 μs
±50.500	1 mV	0.1 % + 4 mV	<150 μV	(0.005% + 200 μV)/°C	250 μs	300 μs
±505.00	10 mV	0.15% + 40 mV	<1.5 mV	(0.008% + 2 mV)/°C	4.5 ms	1 ms

SELECTABLE CURRENT LIMIT: 2.5mA, 250μA, 25μA for 50V and 500V ranges, 25mA additional limit for 10V range. All current limits are –20%/+35% of nominal.

WIDEBAND NOISE⁹: <30mVp-p 0.1Hz–20MHz.

TYPICAL TIME STABILITY: ±(0.003% + 1mV) over 24 hours at constant temperature (within 1°C, between 18°–28°C, after 5 minute settling).

OUTPUT RESISTANCE: <2.5Ω.

VOLTAGE SWEEPS: Supports linear voltage sweeps on fixed source range, one current or resistance measurement per step. Maximum sweep rate: 200 steps per second. Maximum step count 3000. Optional delay between step and measure.

RESISTANCE MEASUREMENT (V/I): Used with voltage source; resistance calculated from voltage setting and measured current. Accuracy is based on voltage source accuracy plus ammeter accuracy. Typical accuracy better than 0.6% for readings between 1kΩ and 1TΩ.

ALTERNATING VOLTAGE RESISTANCE MEASUREMENT: Offers alternating voltage resistance measurements for resistances from 10⁹Ω to 10¹⁵Ω. Alternates between 0V and user-selectable voltage up to ±505V.

NOTES

- At 1 PLC – limited to 60 rdgs/s under this condition.
- At 6 PLC, 1 standard deviation, 100 readings, filter off, capped input – limited to 10 rdgs/sec under this condition.
- Measured at analog output with resistive load >2kΩ.
- Maximum rise time can be up to 25% greater.
- Accuracy does not include output resistance/load regulation.
- Rise Time is from 0V to ± full-scale voltage (increasing magnitude).
- Fall Time is from ± full-scale voltage to 0V (decreasing magnitude).
- For capacitive loads, add C·ΔV/I Limit to rise time, and C·ΔV/1mA to fall time.
- Measured with LO connected to chassis ground.

Specifications are subject to change without notice.

All Keithley trademarks and trade names are the property of Keithley Instruments, Inc. All other trademarks and trade names are the property of their respective companies.

KEITHLEY

Keithley Instruments, Inc.

28775 Aurora Road • Cleveland, Ohio 44139 • 440-248-0400 • Fax: 440-248-6168
1-888-KEITHLEY (534-8453) • www.keithley.com

REMOTE OPERATION

IEEE-488 BUS IMPLEMENTATION: SCPI (IEEE-488.2, SCPI-1996.0); DDC (IEEE-488.1).

LANGUAGE EMULATION: Keithley Model 486/487 emulation via DDC mode.

RS-232 IMPLEMENTATION:

Supports: SCPI 1996.0.

Baud Rates: 300, 600, 1200, 2400, 4800, 9600, 19.2k, 38.4k, 57.6k.

Protocols: Xon/Xoff, 7 or 8 bit ASCII, parity-odd/even/none.

Connector: DB-9 TXD/RXD/GND.

GENERAL

AMMETER INPUT CONNECTOR: Three lug triaxial on rear panel.

ANALOG OUTPUT CONNECTOR: Two banana jacks on rear panel.

VOLTAGE SOURCE OUTPUT CONNECTOR: Two banana jacks on rear panel.

INTERLOCK CONNECTOR: 4 pin DIN.

TRIGGER LINE: Available, see manual for usage.

DISPLAY: 12 character vacuum fluorescent.

DIGITAL FILTER: Median and averaging (selectable from 2 to 100 readings).

RANGING: Automatic or manual.

AUTORANGING TIME³: <250ms (analog filter off, 1PLC)

OVERRANGE INDICATION: Display reads "OVRFLOW".

CONVERSION TIME: Selectable 0.01 PLC to 60 PLC (50PLC under 50Hz operation). (Adjustable from 200μs to 1s)

READING RATE:

- To internal buffer 1000 readings/second¹
- To IEEE-488 bus 900 readings/second^{1,2}

BUFFER: Stores up to 3000 readings.

PROGRAMS: Provide front panel access to IEEE address, choice of engineering units or scientific notation, and digital calibration.

EMC: Conforms with European Union Directive 89/336/EEC, EN61326-1.

SAFETY: Conforms with European Union Directive 73/23/EEC, EN61010-1, CAT I.

ENVIRONMENT:

Operating: 0°–50°C; relative humidity 70% non-condensing, up to 35°C. Above 35°C, derate humidity by 3% for each °C.

Storage: –10°C to +65°C.

WARM-UP: 1 hour to rated accuracy (see manual for recommended procedure).

POWER: 100–120V or 220–240V 50–60Hz, (50VA).

PHYSICAL:

Case Dimensions: 90mm high × 214mm wide × 369mm deep (3½ in. × 8½ in. × 14½ in.).

Working Dimensions: From front of case to rear including power cord and IEEE-488 connector: 394mm (15.5 inches).

NET WEIGHT: <4.7 kg (<10.3 lbs).

Notes:

- 0.01 PLC, digital filters off, front panel off, auto zero off.
- Binary transfer mode. IEEE-488.1.
- Measured from trigger in to meter complete.